

INSTRUCTION MANUAL

FOR

BREAKER FAILURE RELAY

BE1-50BF

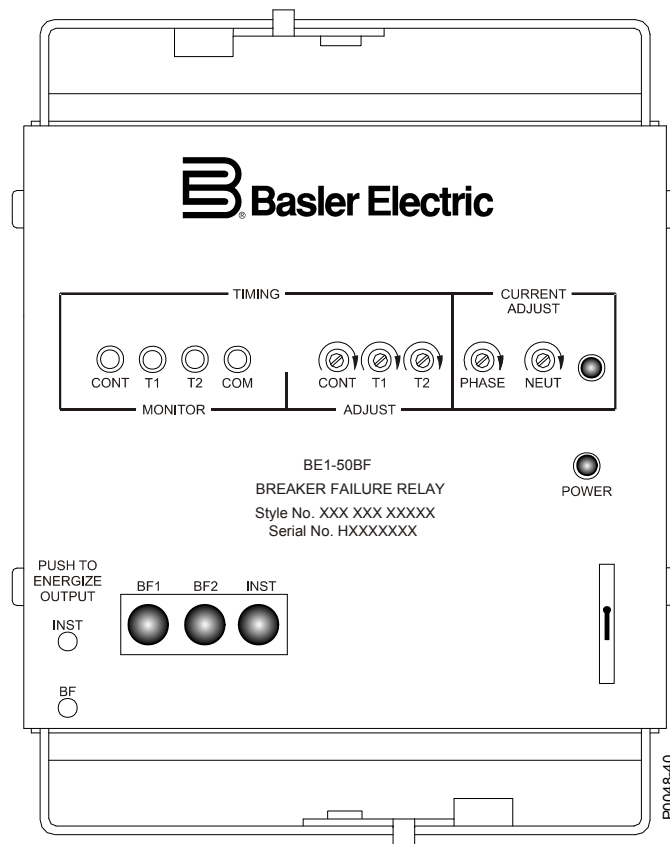

Publication: 9190600990
Revision: G 01/10



INTRODUCTION

This instruction manual provides information about the operation and installation of the BE1-50BF Breaker Failure Relay. To accomplish this, the following information is provided:

- General Information and Specifications
- Controls and Indicators
- Functional Description
- Installation
- Testing

WARNING!

To avoid personal injury or equipment damage, only qualified personnel should perform the procedures in this manual.

NOTE

Be sure that the BE1-50BF is hard-wired to earth ground with no smaller than 12 AWG copper wire attached to the ground terminal on the rear of the unit case. When the BE1-50BF is configured in a system with other devices, it is recommended to use a separate lead to the ground bus from each unit.

First Printing: April 1986

Printed in USA

© 2010 Basler Electric, Highland Illinois 62249 USA

All Rights Reserved

January 2010

CONFIDENTIAL INFORMATION

of Basler Electric, Highland Illinois, USA. It is loaned for confidential use, subject to return on request, and with the mutual understanding that it will not be used in any manner detrimental to the interest of Basler Electric.

It is not the intention of this manual to cover all details and variations in equipment, nor does this manual provide data for every possible contingency regarding installation or operation. The availability and design of all features and options are subject to modification without notice. Should further information be required, contact Basler Electric.

**BASLER ELECTRIC
ROUTE 143, BOX 269
HIGHLAND IL 62249 USA**

<http://www.basler.com>, info@basler.com

PHONE +1 618.654.2341

FAX +1 618.654.2351

REVISION HISTORY

The following information provides a historical summary of the changes made to the BE1-50BF instruction manual (9190600990). Revisions are listed in reverse chronological order.

Manual Revision and Date	Change
G, 01/10	<ul style="list-style-type: none"> • In Figure 1-1, moved Control Timer Setting so that it begins with Timer 1 Setting. • In Figure 4-10, move terminals 15/16 from the lower transformer to the middle transformer.
F, 09/07	<ul style="list-style-type: none"> • Updated output contact ratings and power supply burdens. • Updated front panel illustrations to show laser graphic. • Updated all applicable illustrations to show revised case covers. • Updated Targets description in Section 3, <i>Functional Description</i>. • Added manual part number and revision to footers. • Moved content of Section 6, <i>Maintenance</i> to Section 4. • Moved content of Section 7, <i>Manual Change Information</i> to manual introduction.
E, 08/98	<ul style="list-style-type: none"> • Deleted all references to Service Manual 9190600620. • Replaced Figure 1-1 with a revised Timing diagram. • Corrected Style Chart by changing power supply type Z from “230 Vac” to “240 Vac”. • Changed <i>Current Detector Reset</i> from “Within 1 millisecond at 2 times pickup” to “Less than 1 millisecond.” • Changed Input Voltage Range and Burden Data in Power supply table in <i>Specifications</i>, Section 1. • Updated the Dielectric Test information. • Added RFI information to Specifications. • Corrected <i>Functional Block Diagram</i>. • Replaced Full-Wave Rectifiers and Pickup Comparators with Current Pickup Detector, Current Pickup Indicator, and Current Pickup Output. • Added new power supply information to Section 3 in <i>Power Supply</i> paragraph starting with “Basler Electric enhanced the power supply design...” • Added new dimension figures to include all options available (S1 Double-Ended and both mounting positions). • Added shorting bars to both Internal Connection Diagrams. • Added Option 2, N or S to Control Circuit Diagrams. • Changed “230 Vac” to “240 Vac” in the Contact Sensing Module Diagram. • Removed testing information from Section 4 and added a new Section 5 <i>Testing</i>. • Changed the format of the manual.
D, 03/93	<ul style="list-style-type: none"> • Manual revised to reflect relay modification revision D, affective 03-01-93, serial number 2236, 2295, and subsequent. • Relay dropout specification changed from 5 milliseconds at 2 times pickup to 1 millisecond at 2 times pickup. • Changed Figures 1-1, 2-1, and 3-2. • Added Figures 2-2, 4-1, and 4-2.

Manual Revision and Date	Change
C, 10/92	<ul style="list-style-type: none"> • Added Note 4 to Style Chart in Section 1. • Added specification for pickup tracking accuracy in Section 1.
B, 03/92	<ul style="list-style-type: none"> • Manual revised to reflect the availability of these options not previously offered: Power Supply Status Output (Options 2-A and 2-B).
A, 06/91	<ul style="list-style-type: none"> • Added contact sensing specifications and contact sensing burden chart to Section 1, <i>General Information</i>.
—, 04/86	<ul style="list-style-type: none"> • Initial release

CONTENTS

SECTION 1 • GENERAL INFORMATION.....	1-1
SECTION 2 • CONTROLS AND INDICATORS	2-1
SECTION 3 • FUNCTIONAL DESCRIPTION.....	3-1
SECTION 4 • INSTALLATION.....	4-1
SECTION 5 • TESTING.....	5-1

This page intentionally left blank.

SECTION 1 • GENERAL INFORMATION

TABLE OF CONTENTS

SECTION 1 • GENERAL INFORMATION.....	1-1
DESCRIPTION.....	1-1
Trip Timing.....	1-1
MODEL AND STYLE NUMBER.....	1-2
Style Number.....	1-2
SPECIFICATIONS.....	1-3
Current Sensing.....	1-3
Dropout.....	1-3
Current Detector Reset.....	1-3
Pickup Range.....	1-4
Pickup Accuracy.....	1-4
Pickup Tracking Accuracy (Phase-to-Phase).....	1-4
Contact Recognition Time.....	1-4
Adjustment Range of Control Timer.....	1-4
Adjustment Range of Timer 1 and (optional) Timer 2.....	1-4
Energizing Time of Output Relay.....	1-4
Timing Test Points.....	1-4
Contact Sensing.....	1-4
Contact Sensing Burden.....	1-4
Target Indicators.....	1-4
Power Supply.....	1-4
Output Circuits.....	1-5
Isolation.....	1-5
Radio Frequency Interference (RFI).....	1-5
Surge Withstand Capability.....	1-5
Fast Transient.....	1-5
Impulse Test.....	1-5
Temperature.....	1-5
Shock.....	1-6
Vibration.....	1-6
GOST-R.....	1-6
Weight.....	1-6
Case Size.....	1-6

Figures

Figure 1-1. Timing.....	1-2
Figure 1-2. Style Number Identification Chart.....	1-3

Tables

Table 1-1. Burden (Nominal) Per Non-isolated Sensing Contact.....	1-4
Table 1-2. Power Supplies.....	1-5

This page intentionally left blank.

SECTION 1 • GENERAL INFORMATION

DESCRIPTION

BE1-50BF Breaker Failure Relays are three-phase, solid state relays designed to provide protection and security for the power system against failure of the monitored breaker.

Breaker failure relaying is the use of a current monitoring relay to determine whether or not current continues to flow into a faulted circuit some time after a circuit breaker has been instructed to interrupt the circuit. In the event that current continues to flow into the faulted circuit (after a defined period of time has elapsed sufficient for the breaker to have interrupted the current), then the circuit breaker is considered to have failed, and steps must be initiated to trip the next set of breakers up stream in the power system. The back up scheme must be designed to isolate both the faulted circuit and the failed breaker.

Following are several reasons why a breaker fails to clear a fault:

- Trip circuit can be open (broken wire, blown fuse, open trip coil).
- Interrupting mechanism can stick, leaving a single phase of a three-phase circuit connected.
- Interrupter can flash-over due to the loss of dielectric strength through contamination or damage.
- Operating mechanism can fail to operate.

Breaker failure relays detect these conditions and initiate contingency or back up procedures.

Typically, breaker failure protection is applied to transmission and sub transmission systems. However, breaker failure protection may be applied to any portion of the power system where failure of a circuit breaker to operate properly could result in severe system damage or instability.

Trip Timing

Within the relay are two timers that control operation of the device. Timer 1 defines the delay time between recognition of the breaker trip signal and the interrogation of the current monitoring circuits for the presence of current. Adjustment range for this timer is 18 to 500 milliseconds.

At the same time that timer 1 is initiated, the control timer is also initiated. Figure 1-1 illustrates the trip timing relationships. The purpose of the control timer is to increase security by limiting the response time of the relay to a short period following any given attempt to interrupt the breaker. The control timer also terminates the closure of the BF output relays, and breaks the seal of the seal-in circuit (if used).

Breaker failure initiate (BFI) input seal-in is selected by closing printed circuit board switch S1-3 (refer to Section 2 for location and Section 3 for logic block diagram). This selection may be required when current from an isolated weak source cannot be depended on to maintain the minimum signal level to the protective relays initiating the BFI input. Such a condition can occur when the fault voltage is depressed to zero. The seal-in feature may also counteract contact bounce.

An optional supervisory contact input to the BE1-50BF relay may be specified. When the supervisory contact input is specified, a third timer (timer 2) is built into the relay. Timer 2 (plus associated circuitry together with the supervisory contact) duplicates the corresponding features of the timer 1 system. This addition allows different breaker failure times for different types of failures.

As an example, it might be desirable to use a shorter tripping time if the breaker mechanism fails to operate (all three breaker poles failed to clear the fault). If the mechanism did operate, but only one of the poles failed to clear, a longer breaker failure time might be appropriate. This protection can be provided by connecting the BFI input in series with a 52a contact of the breaker to the supervisory contact input and setting the delay on timer 2 shorter than timer 1. If the breaker mechanism failed to operate, the breaker failure relay would be controlled by timer 2. If the breaker mechanism did operate, timer 2 would (in time) reset and the breaker failure relay would be controlled by timer 1.

This scheme (BFI in series with 52A to supervisory input) allows for 52A or current supervision of the BF timers 1 and 2. If 52A supervision is desired, switch S1-7 would be closed. Refer to Section 3 block diagram for logic details.

This situation requires the following conditions.

- 52a contact must be supervised by the BFI contact input.
- Seal-in feature must not be used.
- Switch S1-4 on the printed circuit board (refer to Section 2 for location) must be closed.

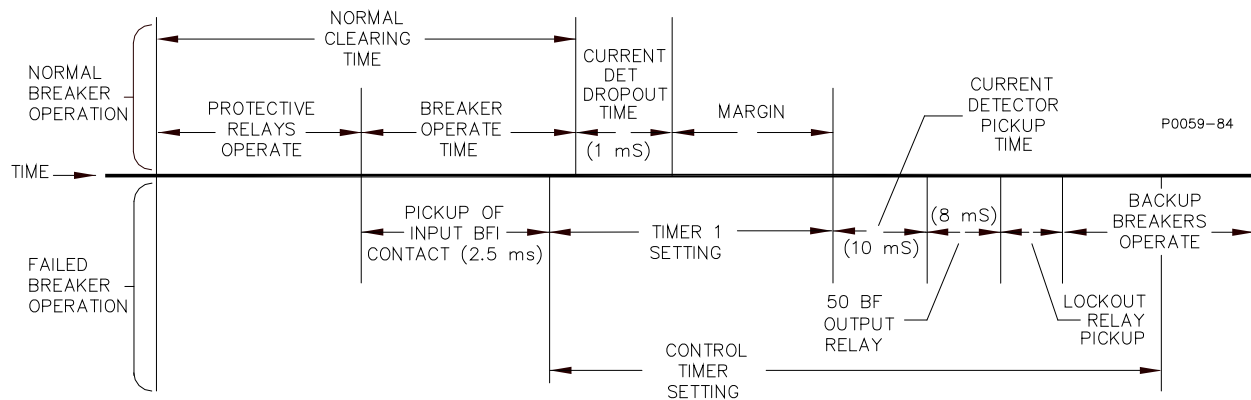

Figure 1-1. Timing

MODEL AND STYLE NUMBER

Style Number

Electrical characteristics and operational features included in a specific relay are defined by the relay style number. The model number and style number appear on the front panel, drawout cradle, and inside the case assembly. Model number BE1-50BF, designates the relay as a Basler Electric Class 100 Breaker Failure Relay. Refer to Figure 1-2 for the style number identification chart.

Sample Style Number

To determine the features in a BE1-50BF relay, style number **F3F-E1J-A4S1F**, refer to the style number identification and the following example.

- F** Three-phase sensing input type.
- 3** Sensing input range 1.0 to 8.0 amperes for all phases.
- F** Three output relays with normally open contacts.
- E1** Definite Timing.
- J** Power supply operates from 125 Vdc or 120 Vac.
- A** Internally operated targets.
- 4** Non-isolated contact sensing.
- S** Push-to-energize outputs (pushbuttons).
- 1** Instantaneous Trip.
- F** Semi-flush mounting.

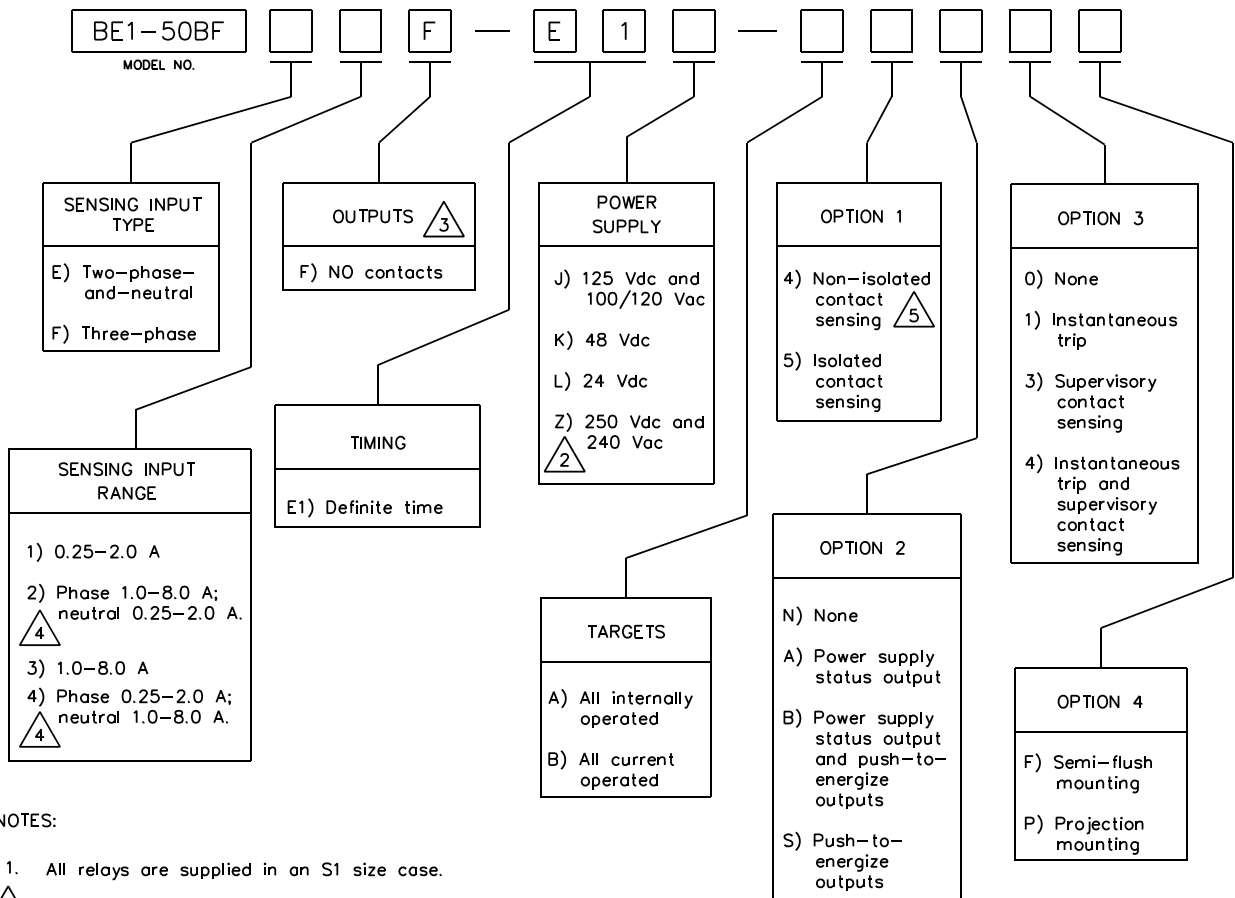

NOTES:

- 1. All relays are supplied in an S1 size case.
- △2 Requires one of the sensing modules listed below.

Contact Sensing Modules (Required when type Z power supply is specified)		
Option 3	Module Ordering No.	
	Isolated Contact Sensing	Non-Isolated Contact Sensing
0 or 1	9 1702 06 105	9 1702 06 111
3 or 4	9 1702 06 104	9 1702 06 110

- △3 When option 2 is N or S, three output relays are provided. When option 2 is A or B, two output relays are provided.
- △4 Sensing input type must be E.
- △5 Requires DC Sensing Power.

D2819-04

Figure 1-2. Style Number Identification Chart

SPECIFICATIONS

The BE1-50BF Breaker Failure Relay has the following features and capabilities.

Current Sensing

Maximum burden of 1 VA per phase at range maximum, 50/60 Hz. Operable over a frequency range of 40 to 70 Hz. Maximum continuous current: 5 A for sensing range of 0.25 to 2.0 A; 10 A for sensing range of 1.0 to 8.0 A. Maximum one second current: 300 A.

For ratings other than one second, the rating may be calculated as follows:

$$I = \sqrt{\frac{K}{t}}$$

where t = the time in seconds, and K = 90,000.

Dropout

Above 98% of actual pickup level.

Current Detector Reset

Less than 1 millisecond.

Pickup Range

Continuously adjustable over the range defined by the style number with independent ranges and adjustments for phase and neutral pickup.

Pickup Accuracy

±2% or ±40 mA of pickup setting, whichever is greater.

Pickup Tracking Accuracy (Phase-to-Phase)

0.25 to 2.0 A range — whichever is greater, 0.025 A or 2% between any two phases.

1.0 to 8.0 A range — whichever is greater, 0.10 A or 2% between any two phases.

Contact Recognition Time

Less than 2.5 milliseconds.

Adjustment Range of Control Timer

150 to 600 milliseconds.

Adjustment Range of Timer 1 and (optional) Timer 2

18 to 500 milliseconds.

Energizing Time of Output Relay

Approximately 8 milliseconds.

Timing Test Points

Oscilloscope test points are provided on the front panel for precise checking of the control timer, as well as timer 1. These nominal 10 V test points are optically coupled to the logic circuits to provide 1,500 V isolation.

Contact Sensing

The sensing circuits require user-supplied contacts with a minimum rating of 0.05 A at 250 Vdc. Sensing current is supplied by the relay in style with isolated sensing. Styles with non-isolated sensing require an applied sensing voltage equal to the relay dc power supply input rating.

Contact Sensing Burden

Burden per contact for non-isolated sensing depends on the power supply type. Refer to Table 1-1.

Table 1-1. Burden (Nominal) Per Non-isolated Sensing Contact

Power Supply Type	Nominal Burden Per Input
J	3.5 W / 5.5 VA
K	3.5 W
L	1.25 W
Z	7.0 W / 20 VA

Target Indicators

Electronically latched LED type targets indicate that an output relay has energized. Targets are manually reset by operating the target reset switch. Either internally operated or current operated targets may be specified. Current operated targets require a minimum of 0.2 A in the output trip circuit, and are rated at 30 A for 1 second, 7 A for 2 minutes, and 3 A continuously.

Power Supply

Power for the internal circuitry may be derived from ac or dc external power sources. Refer to Table 1-2.

Table 1-2. Power Supplies

Type	Input Voltage		Burden at Nominal
	Nominal	Range	
J (mid range)	125 Vdc 120 Vac	24 to 150 Vdc 90 to 132 Vac	5.0 W 12.2 VA
K (mid range)	48 Vdc	24 to 150 Vdc	4.8 W
L (low range)	24 Vdc	12 to 32 Vdc *	4.9 W
Z (high range)	250 Vdc 240 Vac	68 to 280 Vdc 90 to 270 Vac	5.3 W 14.4 VA

* Type L power supply may require 14 Vdc to begin operation. Once operating, the voltage may be reduced to 12 Vdc.

Output Circuits

Resistive Ratings

120 Vac: Make, break, and carry 7 Aac continuously
 250 Vdc: Make and carry 30 Adc for 0.2 s, carry 7 Adc continuously, and break 0.3 Adc
 500 Vdc: Make and carry 15 Adc for 0.2 s, carry 7 Adc continuously, and break 0.3 Adc

Inductive Ratings

120 Vac, 125 Vdc, 250 Vdc: Break 0.3 A (L/R = 0.04)

Isolation

In accordance with IEC 255-5 and ANSI/IEEE C37.90, one minute dielectric (high potential) tests as follows:

All circuits to ground: 2,121 Vdc
 Input to output circuits: 1,500 Vac or 2121 Vdc

Radio Frequency Interference (RFI)

Maintains proper operation when tested for interference in accordance with IEEE C37.90.2-1987, *Standard Withstand Capability of Relay Systems to Radiated Electromagnetic Interference from Transceivers*.

Surge Withstand Capability

Qualified to ANSI/IEEE C37.90.1-1989 *Standard Surge Withstand Capability (SWC) Tests for Protective Relays and Relay Systems*.

Fast Transient

Qualified to ANSI/IEEE C37.90.1-1989.

Impulse Test

Qualified to IEC 255-5.

Temperature

Operating Range

-40° C (-40° F) to 70° C (158° F)

Storage Range

-65° C (-85° F) to 100° C (212° F)

Shock

In standard tests, the relay has withstood 15 g in each of three mutually perpendicular planes without structural damage or degradation of performance.

Vibration

In standard tests, the relay has withstood 2 g in each of three mutually perpendicular planes, swept over the range of 10 to 500 Hz for a total of six sweeps, 15 minutes each sweep, without structural damage or degradation of performance.

GOST-R

GOST-R certified per the relevant standards of Gosstandart of Russia.

Weight

Maximum: 14.1 lb (6.4 kg)

Case Size

S1 (Refer to Section 4 for case dimensions.)

SECTION 2 • CONTROLS AND INDICATORS

TABLE OF CONTENTS

SECTION 2 • CONTROLS AND INDICATORS	2-1
INTRODUCTION.....	2-1

Figures

Figure 2-1. Location of Controls and Indicators	2-2
Figure 2-2. Location of Field Programmable Switch S1	2-3

Tables

Table 2-1. BE1-50BF Controls and Indicators (Refer to Figure 2-1).....	2-1
Table 2-2. Field Programmable Switch S1	2-2

This page intentionally left blank.

SECTION 2 • CONTROLS AND INDICATORS

INTRODUCTION

BE1-50BF controls and indicators are located on the front panel and the left interior. The controls and indicators are shown in Figures 2-1 and 2-2. Table 2-1 references the callouts in Figure 2-1. Table 2-2 references Figure 2-2.

Table 2-1. BE1-50BF Controls and Indicators (Refer to Figure 2-1)

Locator	Control or Indicator	Function
A thru D	TIMING MONITOR Test Points	Jacks provide nominal 10 V oscilloscope test points for monitoring the control timer, timer T1, and timer T2. The jacks accommodate a standard 0.080 diameter phone tip plug.
E thru G	CONT, T1, T2, TIMING ADJUST	Multiturn potentiometers allow screwdriver adjustment of timers (control, T1, and (optional) T2).
H	PHASE CURRENT ADJUST Pickup Control	Multiturn potentiometer establishes the pickup point for phase current. Continuously adjustable over the range defined by the style number.
I	NEUTral CURRENT ADJUST Pickup Control	Multiturn potentiometer establishes the pickup point for neutral current. Continuously adjustable over the range defined by the style number.
J	Current Pickup Indicator	LED lights when current exceeds the pickup point on any monitored phase (or neutral). The lamp extinguishes as soon as all monitored inputs drop below pickup.
K	POWER LED	LED illuminates to indicate that power supply is operating.
L	Target Reset Switch	This switch resets the target indicators.
M	BF1, BF2, INST Target Indicators (optional)	Electronically latching red indicators illuminate when the associated output relay has been energized.
N	PUSH-TO-ENERGIZE OUTPUT (optional)	Momentary pushbuttons accessible by inserting a 1/8 inch diameter non-conducting rod through the front panel. Pushbuttons are used to energize the output relays in order to test system wiring.

CAUTION

If S1-3 is closed and pickup current present, the push-to-energize switch for the instantaneous output will also close the breaker failure output.

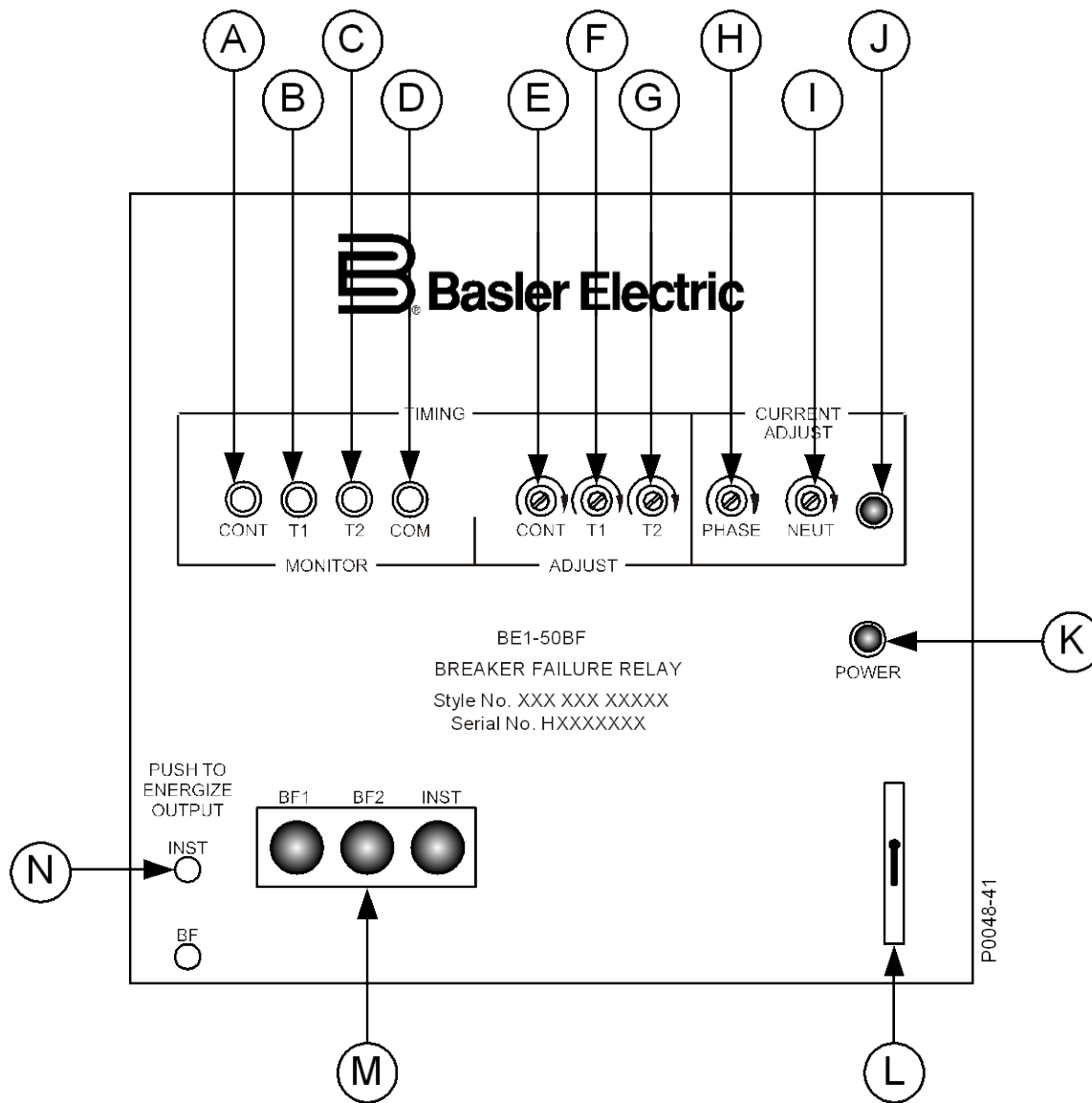

Figure 2-1. Location of Controls and Indicators

Table 2-2. Field Programmable Switch S1

Switch Section	Function
1	When ON (down), enables the (optional) instantaneous relay whenever a BFI contact closure occurs. The Instantaneous relay will reset at the expiration of the BFI signal, or at the end of the control timer cycle, whichever comes first.
2	When ON (down), enables the (optional) instantaneous relay whenever a supervisory input occurs. The relay will reset at the expiration of the supervisory signal, or at the end of the control timer cycle, whichever comes first.
3	S1-3 is NOT functional unless S1-1, S1-2, or both switches are in the ON (down) position. With S1-3 closed and a recognized BFI input, the instantaneous output is held activated until the control timer times out.
4	When ON (down), allows the supervisory contacts to initiate a preset timing sequence that duplicates the BFI timing circuit. The preset time for the two timers may be different. In this mode, either set of input contacts can initiate a sequence that enables the output relay when T1 or T2 and the control timer has timed out.

Switch Section	Function
5	When ON (down), inhibits operation of the output relays unless the supervisory contacts are closed.
6	When ON (down), the output relays are inhibited until both the T1 and T2 timers have cycled. At this time, a sensed current above pickup will energize the output relay.
7	When ON (down), a BF output will occur after the expiration of Timer 1 if the supervisory contact is closed, regardless of the presence or absence of sensing current.
8	When ON (down), requires closure of the supervisory contact, and completion of both T1 and T2 timing cycles to energize the BF output relays. In this case, sensed current need not be present. However, if T1 times out before T2, and if sensing current is above pickup, a BF output will occur.

NOTE

Switches seven and eight may be used for conducting system tests. Note that a BFI output can be obtained WITHOUT the presence of line current.

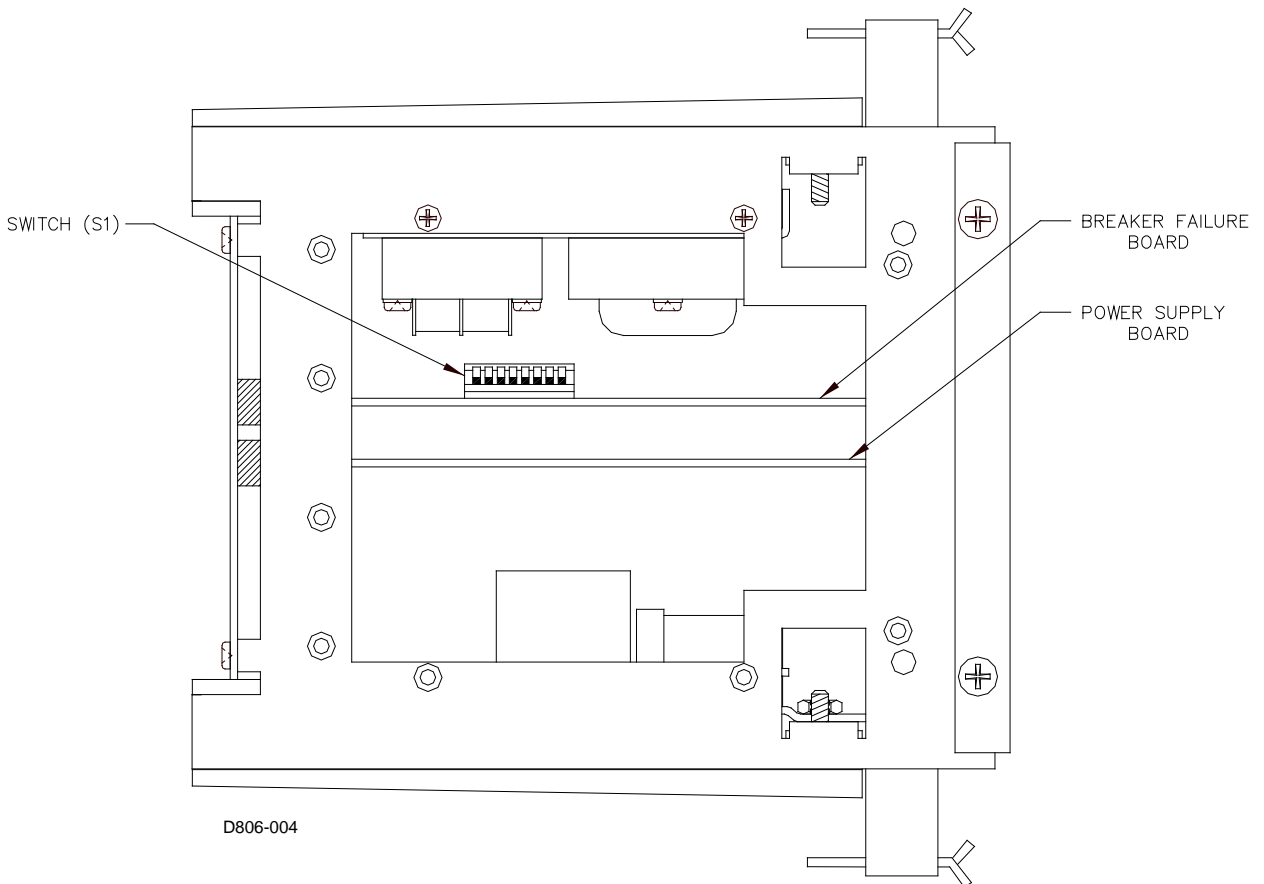

Figure 2-2. Location of Field Programmable Switch S1

This page intentionally left blank.

SECTION 3 • FUNCTIONAL DESCRIPTION

TABLE OF CONTENTS

SECTION 3 • FUNCTIONAL DESCRIPTION.....	3-1
GENERAL	3-1
FUNCTIONAL DESCRIPTION	3-1
Contact Sensing	3-1
Instantaneous Output - Optional	3-1
Control Timer.....	3-2
Timer T1 and T2.....	3-2
Field Programmable Logic	3-2
Outputs	3-2
Current Sensing	3-2
Current Pickup Detector	3-2
Current Pickup Indicator.....	3-2
Current Pickup Output.....	3-3
Pickup Settings.....	3-3
Power Supply	3-3
Power Supply Status Contacts.....	3-3
Target Indicators	3-3
Figures	
Figure 3-1. Functional Block Diagram	3-1
Figure 3-2. Control Timer Cycle	3-2

This page intentionally left blank.

SECTION 3 • FUNCTIONAL DESCRIPTION

GENERAL

BE1-50BF Breaker Failure Relays are static devices designed to detect circuit breaker failure, and to trip backup circuit breakers when such failures are detected.

FUNCTIONAL DESCRIPTION

Relay circuit functions illustrated in Figure 3-1 are described in the following paragraphs.

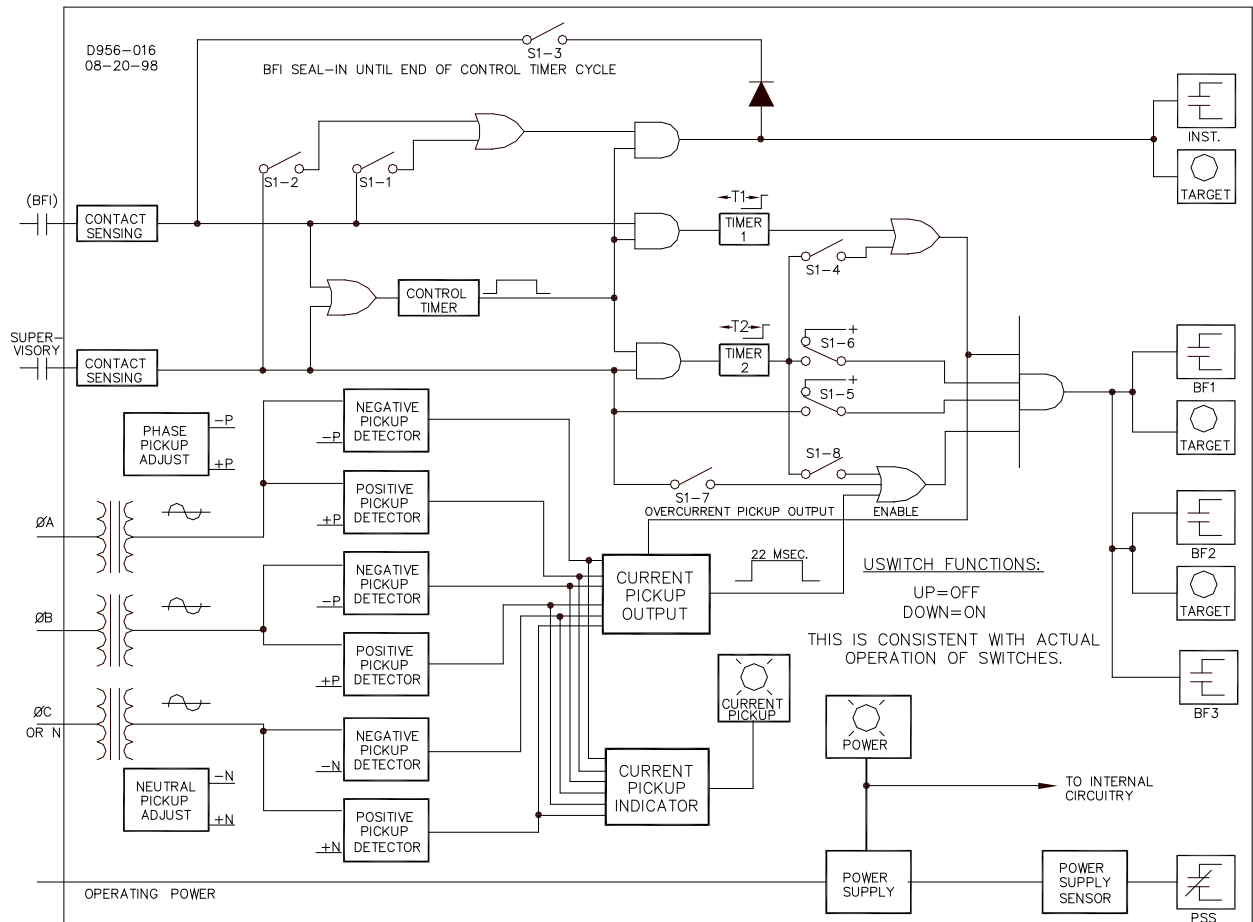

Figure 3-1. Functional Block Diagram

Contact Sensing

Before any relay output can occur, there must first be an initiating signal from external contacts. Two possible initiating signals are either the breaker failure initiate (BFI) signal or the optional supervisory signal. Contact sensing circuitry allows the relay to monitor external contacts for the presence of these signals.

Contact sensing inputs must use either isolated sensing or non-isolated sensing. Isolated sensing (option 1-5) uses current supplied by the relay to monitor external contacts. Non-isolated sensing uses an external dc source to monitor the contacts. Nominal voltages of the external dc source must match the dc input voltages of the relay power supply. If the power supply of the relay has an ac source, a separate dc source must be utilized for the contact sensing input.

Instantaneous Output - Optional

Instantaneous output relays are enabled whenever a BFI contact closure and enabling switch S1-1 is closed. They are also enabled whenever a supervisory contact closure is detected and enabling switch S1-2 is closed. S1-3, when closed, seals the instantaneous relays through the BFI input. Instantaneous

output relays remain enabled until the control timer times out, and reset when the control timer times out. If S1-3 is open, instantaneous output relays remain enabled only for the period of time that the BFI or supervisory contacts are closed. Two instantaneous output relays are provided.

Control Timer

The control timer provides a window of opportunity for a breaker failure output. Control timer cycles are initiated by either a BFI or supervisory input signal. For the breaker failure output contacts to close as shown in Figure 3-2, the sensed current must be in excess of the pickup setting. Note that all output relays, if operated, are restored at the end of the control timer cycle.

To facilitate setting the relay, four oscilloscope test jacks are provided on the front panel (A through D, Figure 2-1). These jacks are completely isolated from all other circuits.

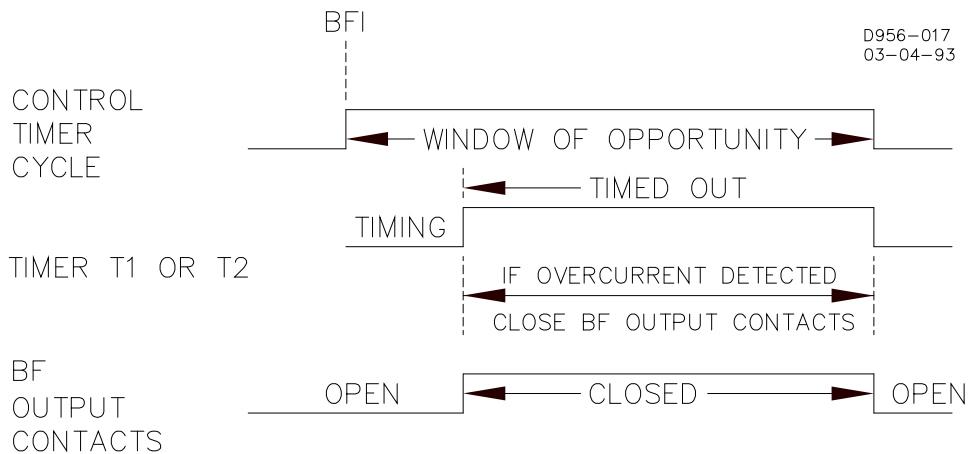

Figure 3-2. Control Timer Cycle

Timer T1 and T2

Timers T1 and T2 provide (independently) an adjustable time delay to allow current to decay after the breaker is tripped. If sensed current is in excess of the pickup setting and the timer times out while the window of opportunity is present (before the control timer times out), the BF output contacts will close.

Field Programmable Logic

Field programmable switch S1 is an eight section switch (S1-1 through S1-8) that allows the relay to be reconfigured to meet changing requirements. Switch S1 is located on left side of the logic board and is accessible by withdrawing the cradle assembly from the case. The purpose of each switch section is explained in detail in Section 2.

Outputs

Breaker failure output relays, BF1 through BF3, are simultaneously operated when the associated logic AND function receives qualifying signals.

Current Sensing

Monitored line currents are applied to the Primaries of internal current transformers and stepped down to internal circuit levels. Transformers provide a high degree of isolation.

Current Pickup Detector

Each sensing input is fed to both a positive and negative half cycle pickup detector. Each detector will provide an output when the sensing current increases to a level greater than the pickup setting.

Current Pickup Indicator

Each current pickup detector provides an input to the current pickup indicator. The current pickup indicator turns ON the LED for 22 milliseconds after the most recent input. Outputs are approximately every eight milliseconds for the duration of time that the sensing current is above the pickup setting.

Current Pickup Output

Each current pickup detector provides an input to the current pickup output. The current pickup output provides an output to the logic if enabled by timer 1.

Pickup Settings

A front panel, multi-turn potentiometer sets the phase currents pickup thresholds. A second potentiometer is provided to establish the neutral current pickup threshold.

Power Supply

Operating power for the relay circuitry is supplied by a wide range, electrically isolated, low-burden power supply. Power supply operating power is not polarity sensitive. The front panel power LED and power supply status output indicate when the power supply is operating. Power supply specifications are listed in Table 1-1.

Power Supply Status Contacts

Power supply output contacts are monitored at the mother board. Normal supply voltage causes the status relay to be continually energized. However, if at any time the voltage falls below requirements, the relay drops out, and closes the normally closed contacts.

Target Indicators

Target indicators are optional components selected when a relay is ordered. The electronically latched and reset targets consist of red LED indicators located on the relay front panel. A latched target is reset by operating the target reset switch on the front panel. If relay operating power is lost, any illuminated (latched) targets are extinguished. When relay operating power is restored, the previously latched targets are restored to their latched state.

A relay can be equipped with either internally operated targets or current operated targets.

Internally Operated Targets

The relay trip outputs are directly applied to drive the appropriate target indicator. Each indicator is illuminated regardless of the current level in the trip circuit.

Current Operated Targets

A current operated target is triggered by closure of the corresponding output contact and the presence of at least 200 milliamperes of current flowing in the trip circuit.

NOTE

Prior to September 2007, BE1-50BF target indicators consisted of magnetically latched, disc indicators. These mechanically latched target indicators have been replaced by the electronically latched LED targets in use today.

This page intentionally left blank.

SECTION 4 • INSTALLATION

TABLE OF CONTENTS

SECTION 4 • INSTALLATION.....	4-1
INTRODUCTION.....	4-1
RELAY OPERATING GUIDELINES AND PRECAUTIONS	4-1
MOUNTING.....	4-1
CONNECTIONS.....	4-7
MAINTENANCE.....	4-11
STORAGE.....	4-11

Figures

Figure 4-1. Outline Dimensions, Side View, Semi-Flush Mounted, Double-Ended Case.....	4-2
Figure 4-2. Outline Dimensions, Side View, Projection Mounted, Double-Ended Case.....	4-3
Figure 4-3. Outline Dimensions, Front View, Case Cover.....	4-4
Figure 4-4. Panel Drilling Dimensions, Projection Mounting, Double-Ended Case	4-5
Figure 4-5. Panel Cutting and Drilling Dimensions, Semi-Flush Mounting, Double-Ended Case.....	4-6
Figure 4-6. Typical Internal Connections, Sensing Input Type E.....	4-7
Figure 4-7. Typical Internal Connections, Sensing Input Type F	4-8
Figure 4-8. Control Circuit Connections (Typical) Non-Isolated Inputs	4-9
Figure 4-9. Control Circuit Connections (Typical) Isolated Inputs.....	4-9
Figure 4-10. Typical Connections Sensing Input Type E.....	4-10
Figure 4-11. Typical Connections Sensing Input Type F	4-10
Figure 4-12. Contact Sensing Modules, Power Supply Z.....	4-11

This page intentionally left blank.

SECTION 4 • INSTALLATION

INTRODUCTION

BE1-50BF relays are shipped in sturdy cartons to prevent damage during transit. Upon receipt of a relay, check the model and style number against the requisition and packing list to see that they agree. Inspect the relay for shipping damage. If there is evidence of damage, file a claim with the carrier, and notify your sales representative or Basler Electric.

If the relay will not be installed immediately, store it in its original shipping carton in a moisture- and dust-free environment. Before placing the relay in service, it is recommended that the test procedures of Section 5, *Testing* be performed.

RELAY OPERATING GUIDELINES AND PRECAUTIONS

Before installing or operating the relay, note the following guidelines and precautions.

- For proper current operated target operation, a minimum current of 200 milliamperes must flow through the output trip circuit.
- If a wiring insulation test is required, remove the connection plugs and withdraw the relay from its case.

CAUTION

When the connection plugs are removed, the relay is disconnected from the operating circuit and will not provide system protection. Always be sure that external operating (monitored) conditions are stable before removing a relay for inspection, test, or service.

NOTE

Be sure that the relay is hard-wired to earth ground with no smaller than 12 AWG copper wire attached to the ground terminal on the rear of the case. When the relay is configured in a system with other devices, it is recommended to use a separate lead to the ground bus from each device.

MOUNTING

Because the relay is of solid-state design, it does not have to be mounted vertically. Any convenient mounting angle may be chosen. Refer to Figures 4-1 through 4-5 for relay outline dimensions and panel drilling diagrams.

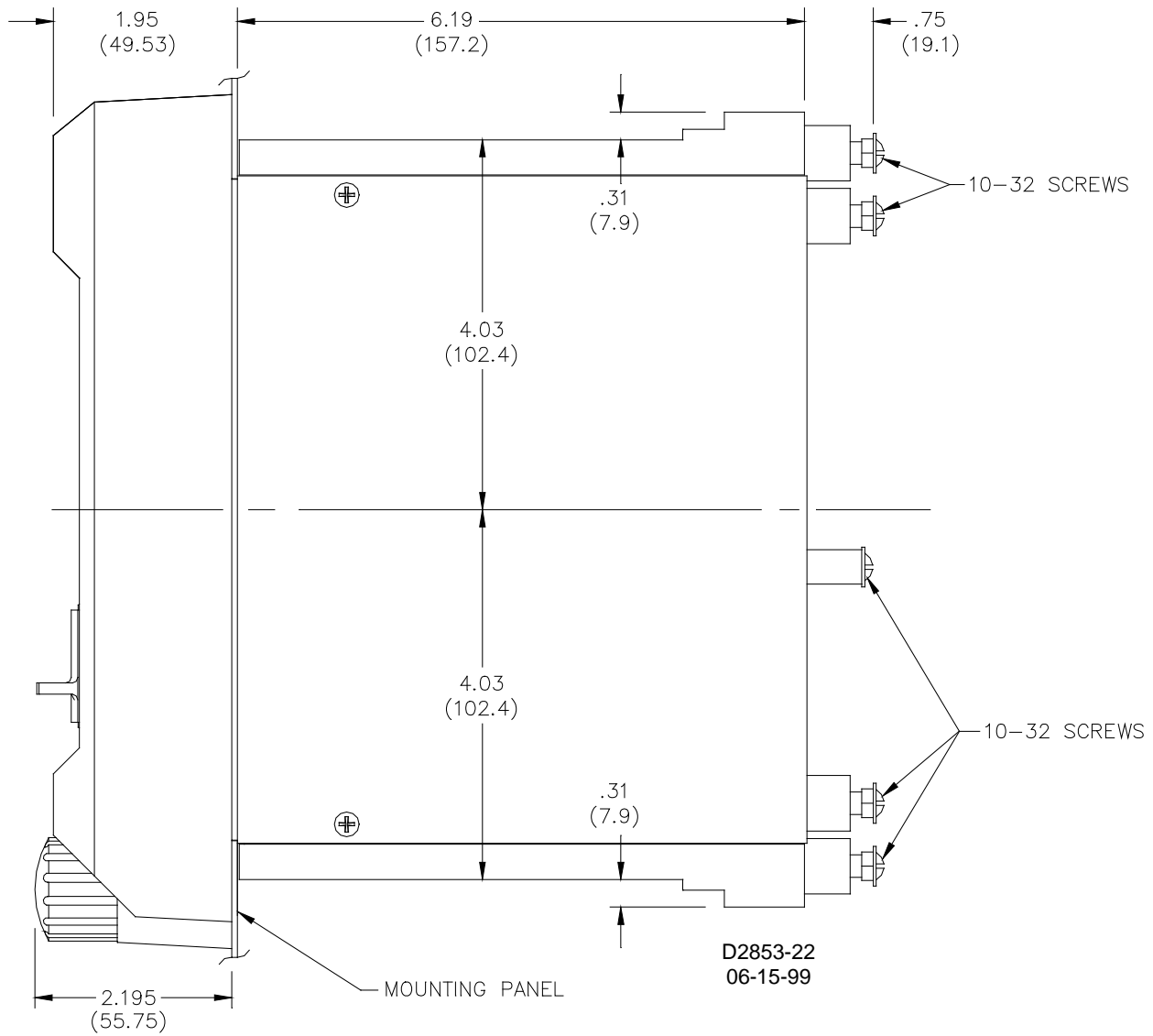

Figure 4-1. Outline Dimensions, Side View, Semi-Flush Mounted, Double-Ended Case

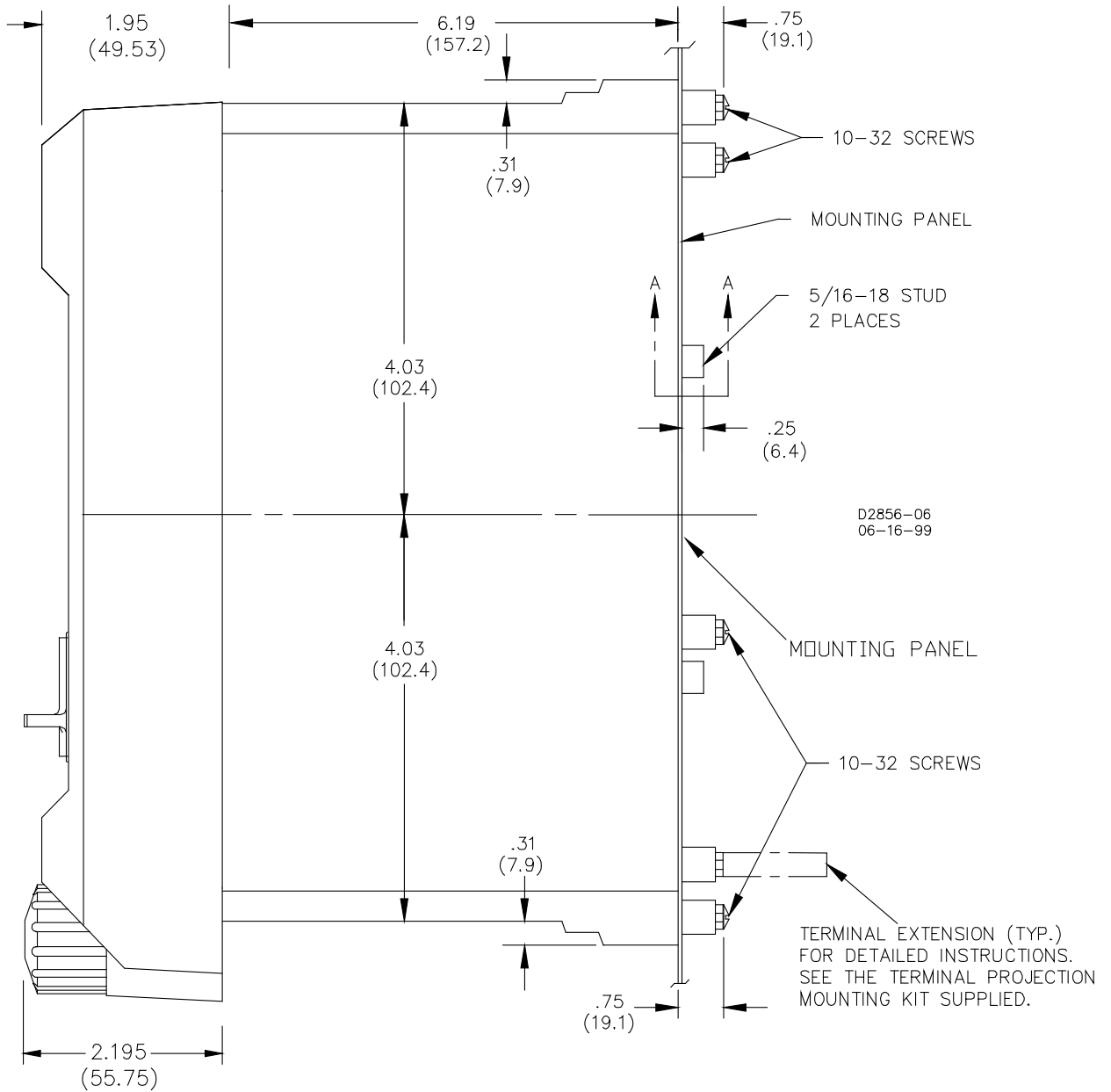

Figure 4-2. Outline Dimensions, Side View, Projection Mounted, Double-Ended Case

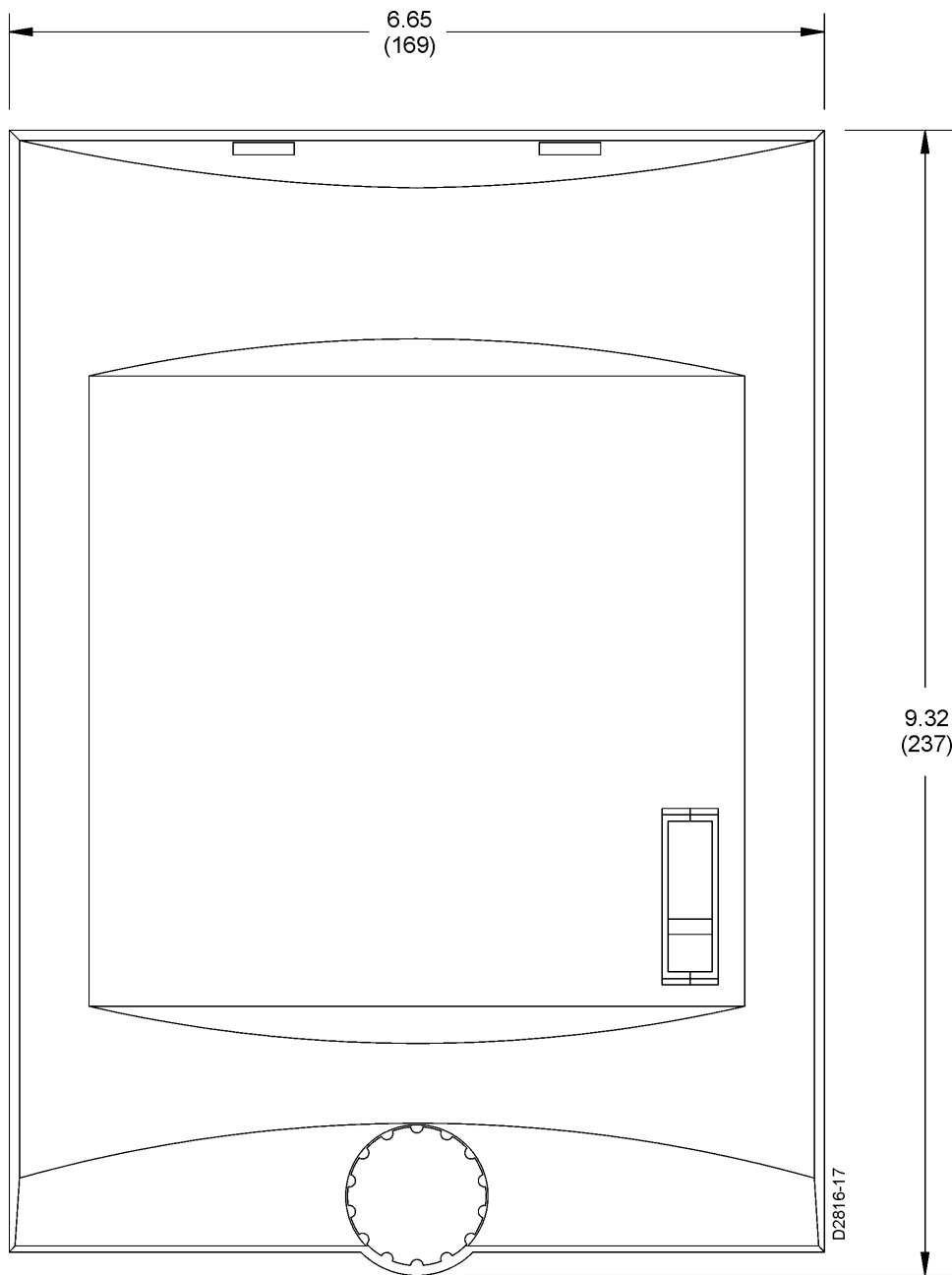

Figure 4-3. Outline Dimensions, Front View, Case Cover

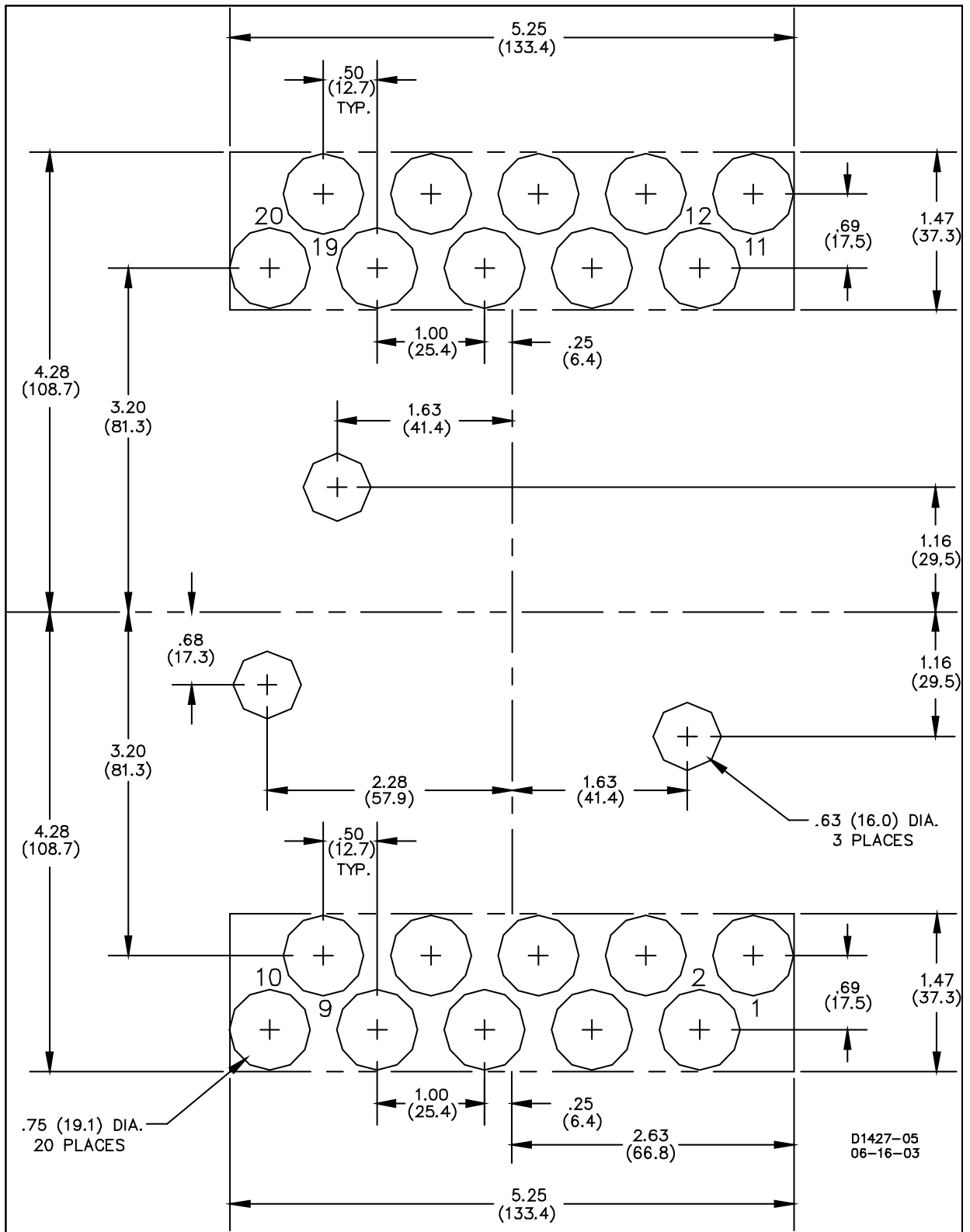

Figure 4-4. Panel Drilling Dimensions, Projection Mounting, Double-Ended Case

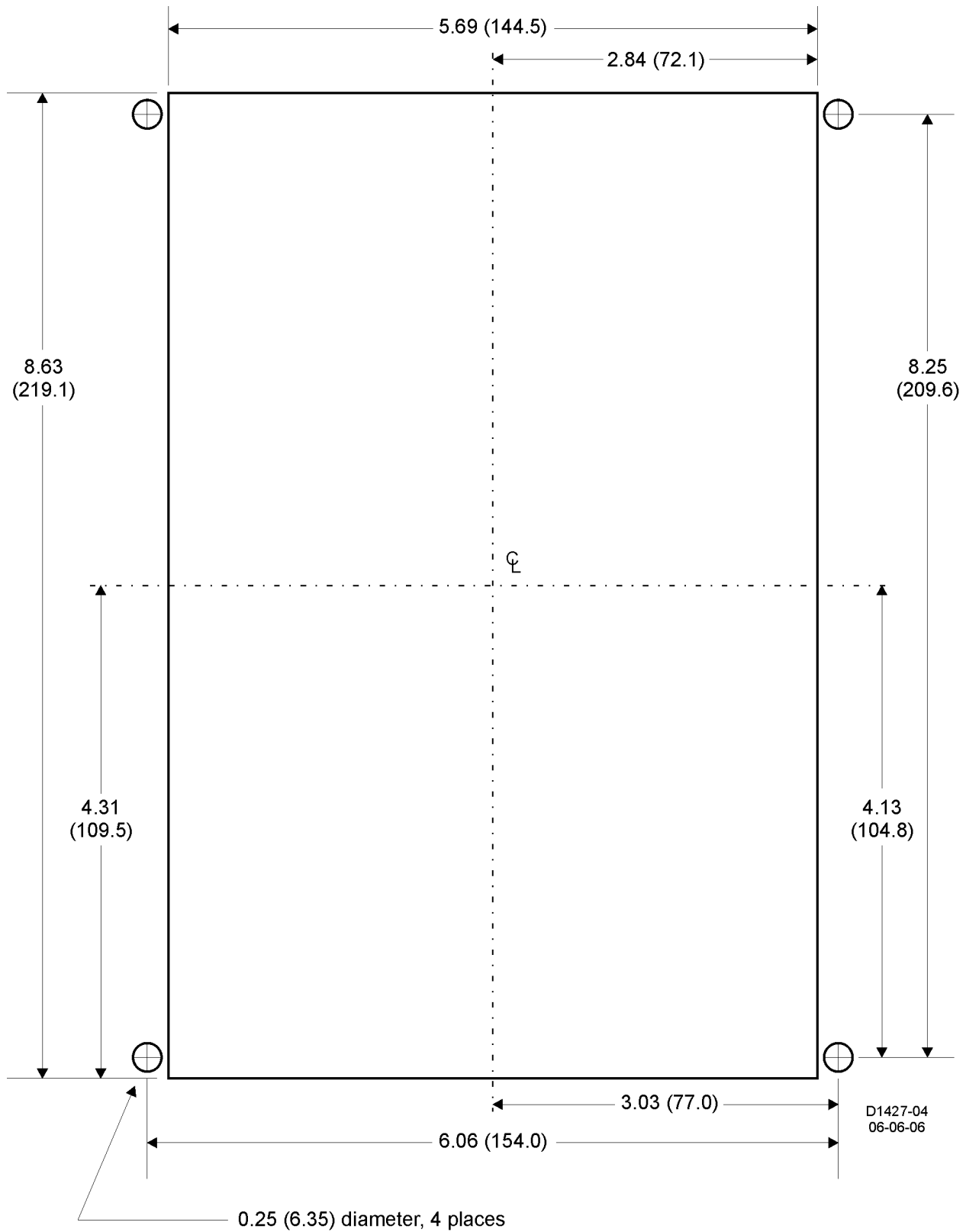

Figure 4-5. Panel Cutting and Drilling Dimensions, Semi-Flush Mounting, Double-Ended Case

CONNECTIONS

Be sure to check the model and style number of a relay before connecting and energizing the relay. Incorrect wiring may result in damage to the relay. Except where noted, connections should be made with wire no smaller than 14 AWG.

Typical internal connections are shown in Figures 4-6 and 4-7. External connections are shown in Figures 4-8 through 4-11.

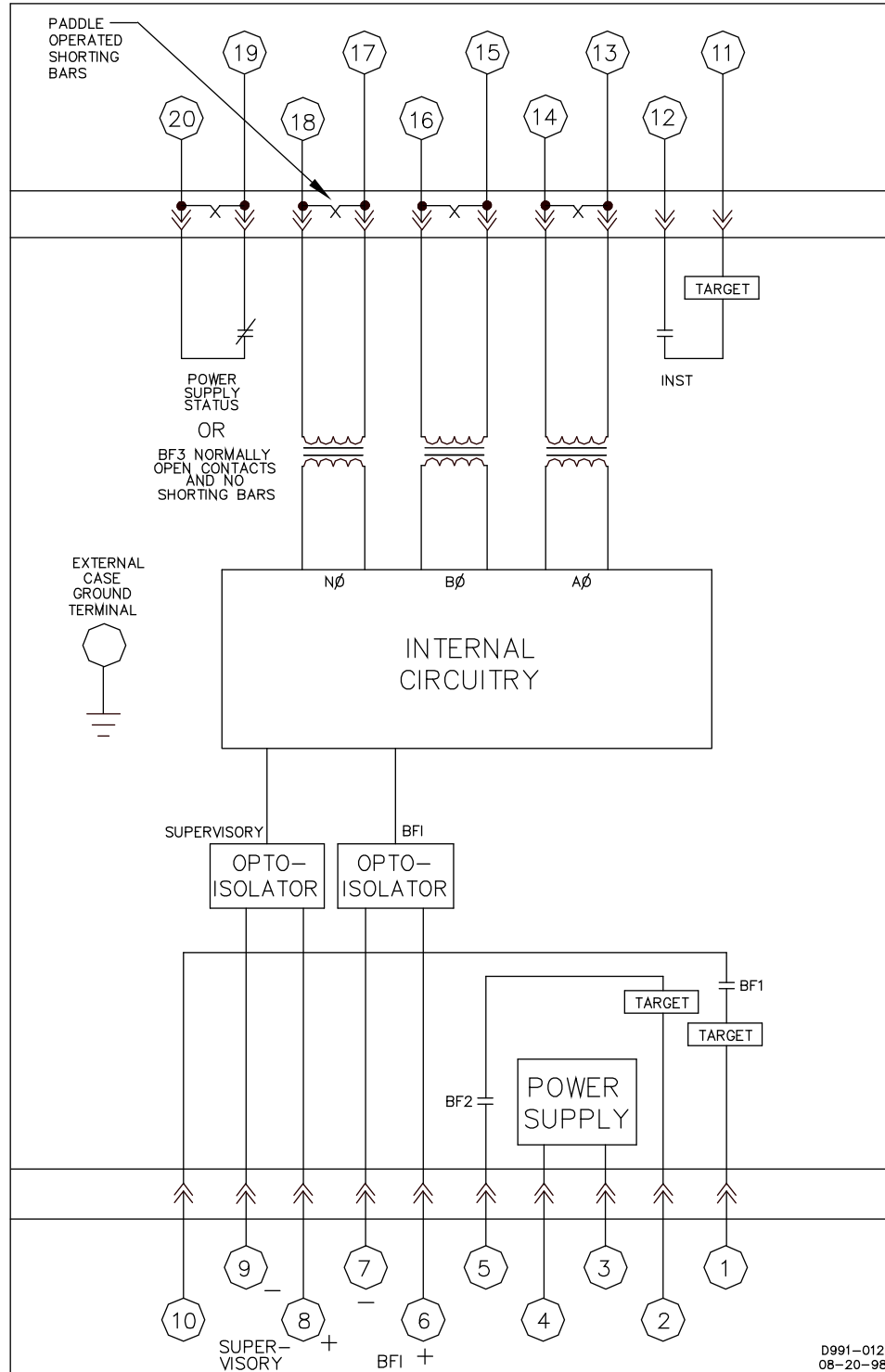

Figure 4-6. Typical Internal Connections, Sensing Input Type E

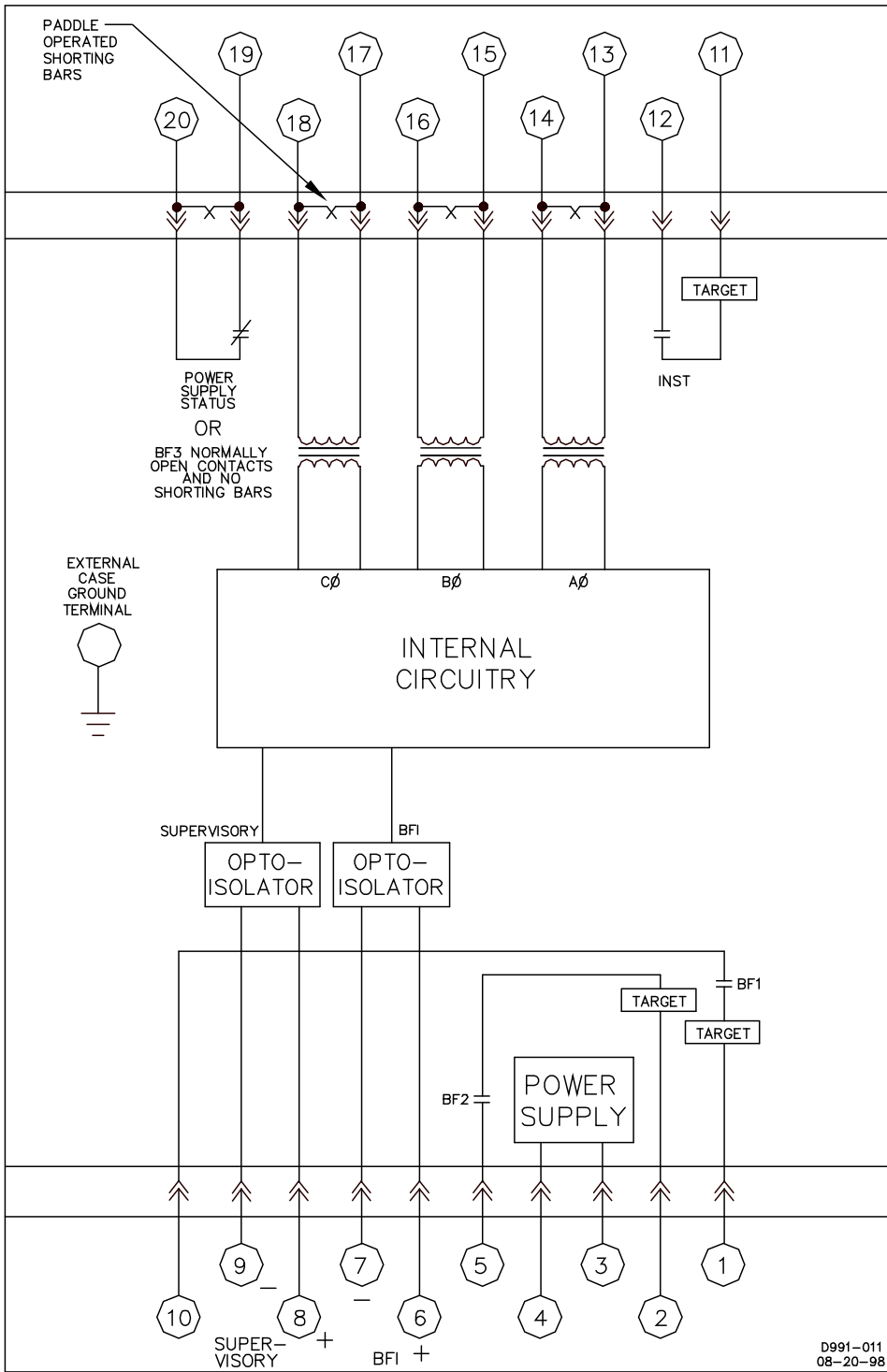

Figure 4-7. Typical Internal Connections, Sensing Input Type F

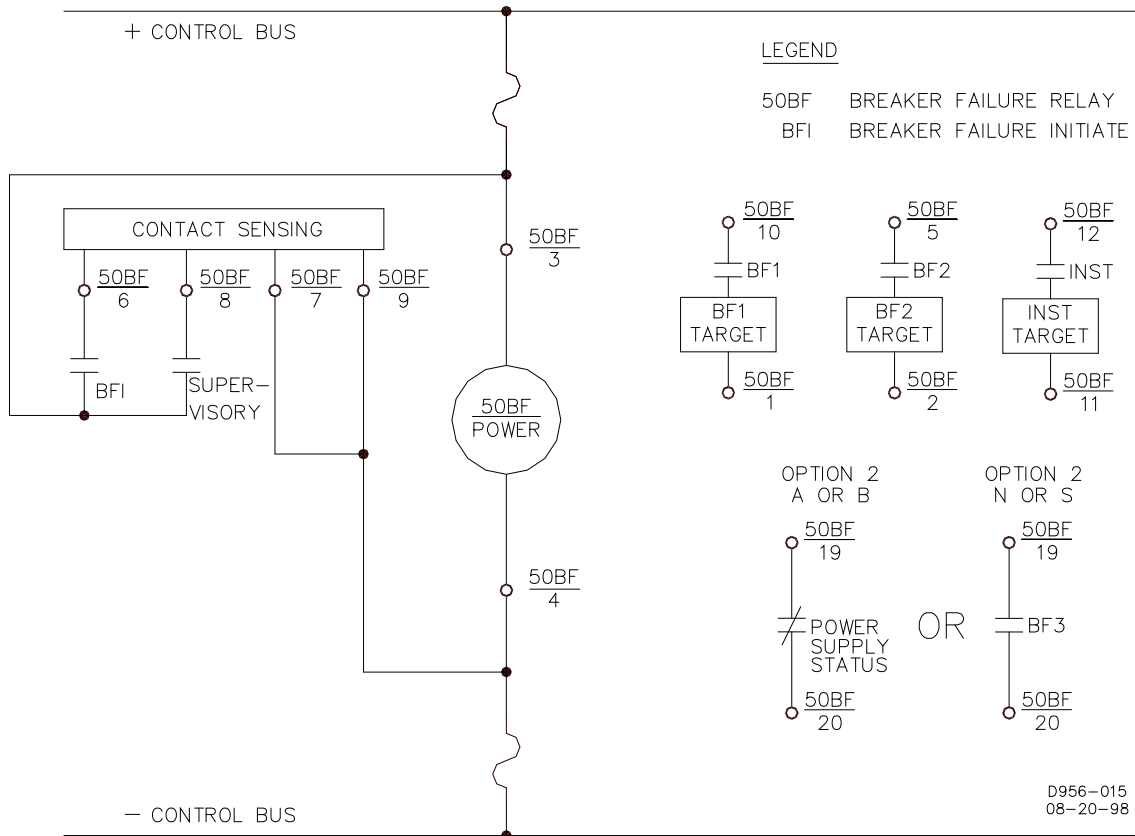

Figure 4-8. Control Circuit Connections (Typical) Non-Isolated Inputs

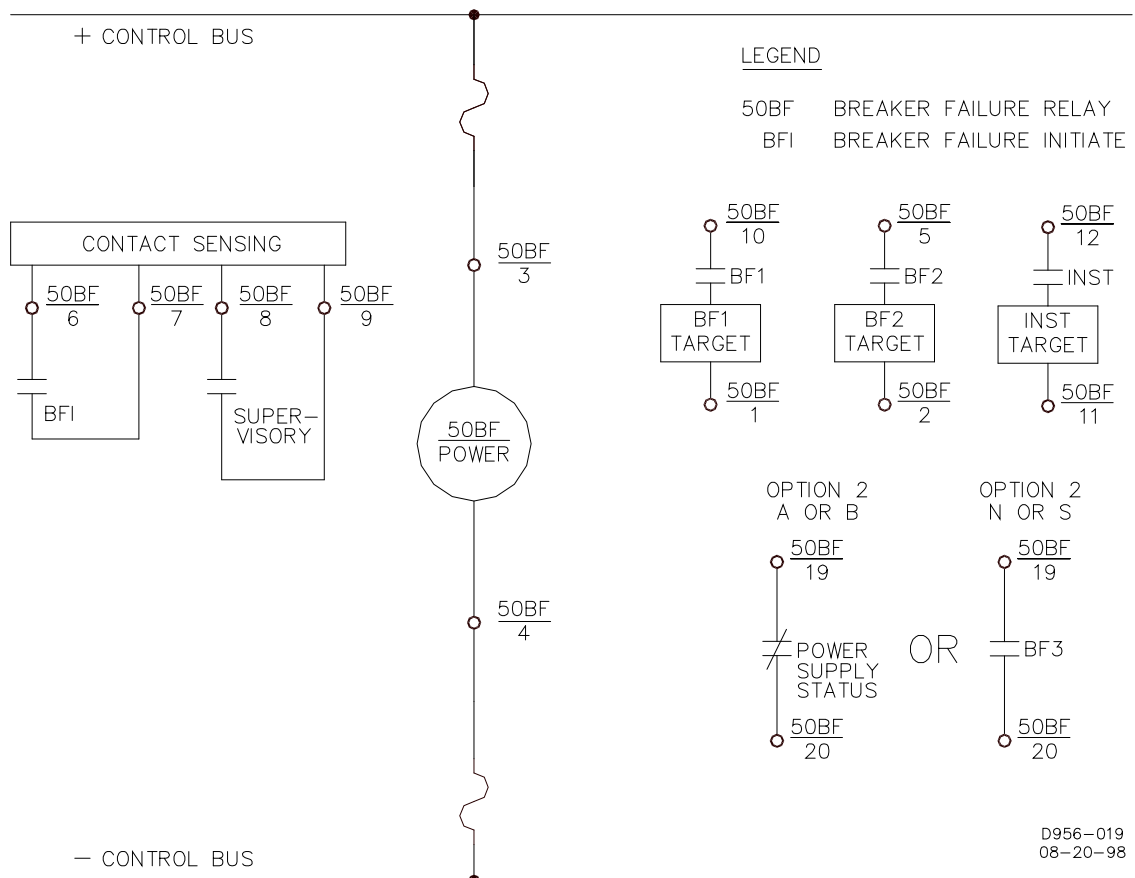

Figure 4-9. Control Circuit Connections (Typical) Isolated Inputs

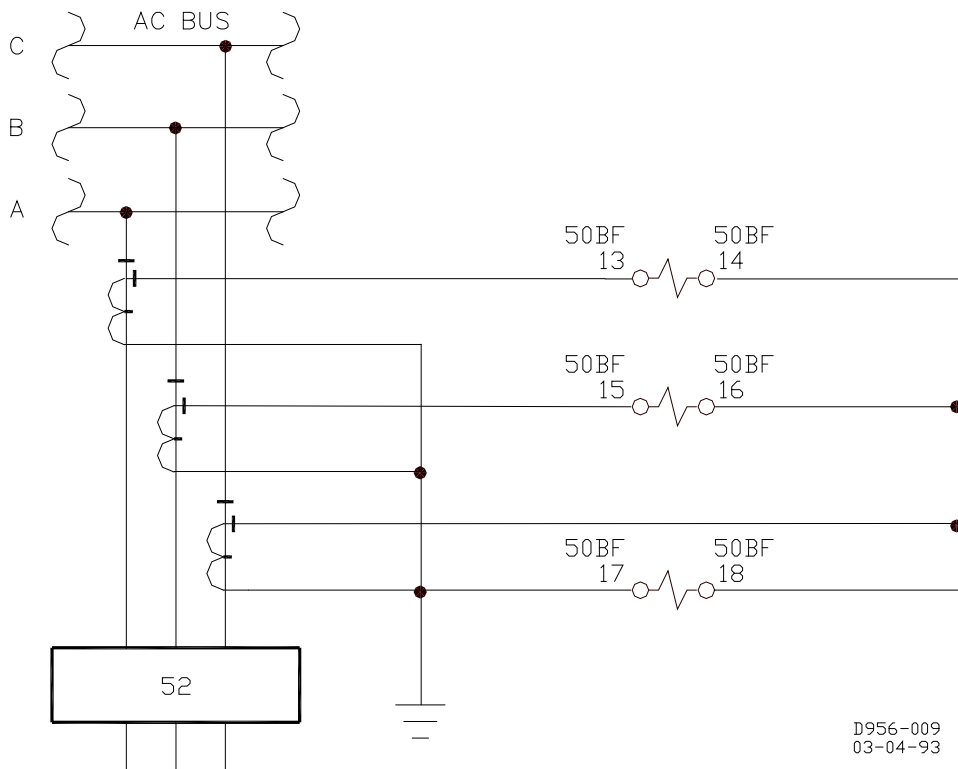

Figure 4-10. Typical Connections Sensing Input Type E

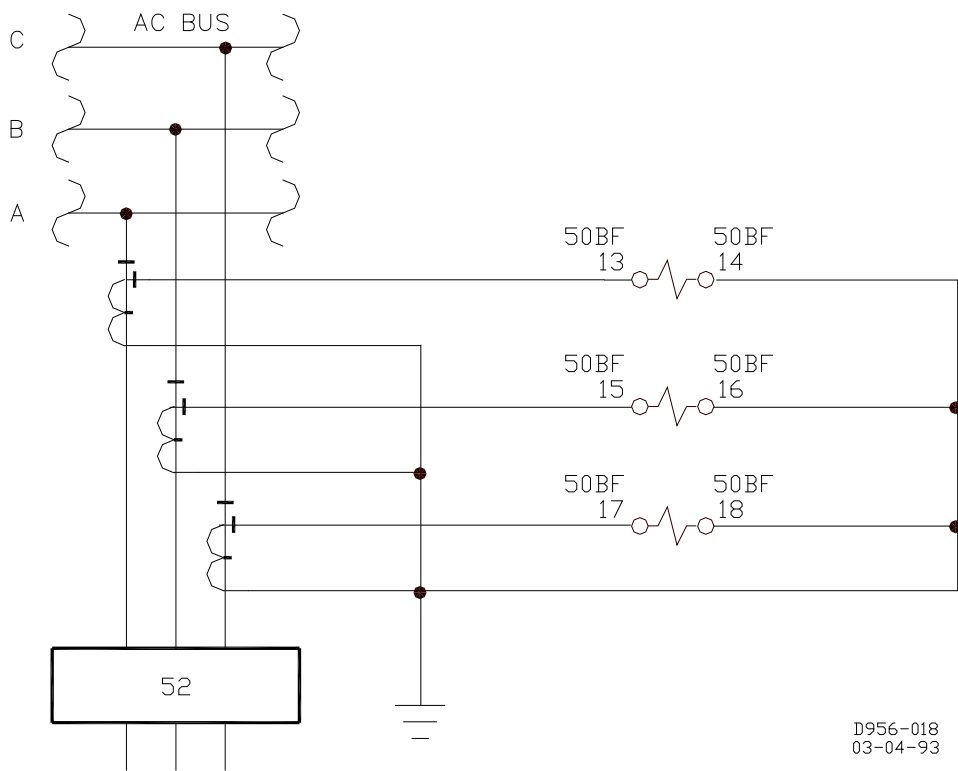

Figure 4-11. Typical Connections Sensing Input Type F

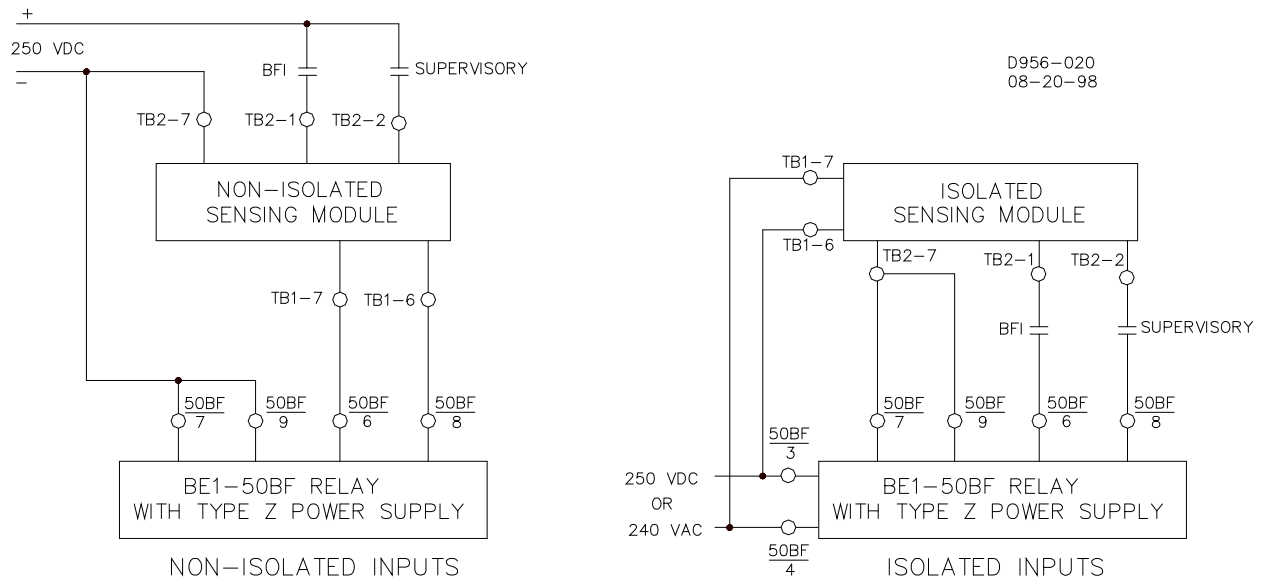

Figure 4-12. Contact Sensing Modules, Power Supply Z

MAINTENANCE

BE1-50BF relays require no preventative maintenance other than a periodic operational check. If the relay fails to function properly, contact Technical Sales Support at Basler Electric to coordinate repairs.

STORAGE

This device contains long-life electrolytic capacitors. For devices that are not in service (spares in storage), the life of these capacitors can be maximized by energizing the device for 30 minutes once per year.

This page intentionally left blank.

SECTION 5 • TESTING

TABLE OF CONTENTS

SECTION 5 • TESTING.....	5-1
OPERATIONAL TEST PROCEDURE	5-1

This page intentionally left blank.

SECTION 5 • TESTING

CAUTION

Before performing the following tests, refer to the relay operating precautions in Section 4.

OPERATIONAL TEST PROCEDURE

The following test procedure verifies operation and calibration of the relay. Note that the results obtained from this procedure may not fall strictly within specified tolerances. When evaluating results, consider the inherent error of test equipment. Test equipment should be accurate within 1% or better.

- Step 1. On the logic board (left side), find S1 and set S1-4 to ON (down) and all other switches to OFF (up).
- Step 2. Apply appropriate operating power to terminals 3 and 4. Verify that the POWER LED is ON and power supply status contacts (if supplied) are open.
- Step 3. Apply a variable source of ac current to phase A, terminals 13 and 14. Range of current source should be appropriate to the sensing input range.
- Step 4. Turn the phase pickup adjustment fully CCW. From near zero, slowly increase current from the variable current source until the current pickup indicator on front panel lights. Measure the current. It should be at or below the low end of the sensing input range.
- Step 5. Turn the phase pickup adjustment fully CW. Slowly increase current until the current pickup indicator lights. Measure the current. It should be at or above the high end of the sensing input range.
- Step 6. Repeat steps 3 (substitute appropriate terminals for terminals 13 and 14), 4, and 5 for each phase and neutral (if supplied). Note that the neutral sensing input range may be different than the phase sensing input range.
- Step 7. Set the control timer to its maximum period (potentiometer fully CW). Set timers T1 and T2 to their minimum period (both potentiometers fully CCW).
- Step 8. Provide a means for monitoring contact closure for the three BF outputs (terminals 1 and 10, 2 and 5, 11 and 12). If current operated targets are supplied, there must be at least 0.2 A flowing through the contacts when closed. Reset targets (if supplied).
- Step 9. Apply a current to any sensing input so that the current pickup indicator LED is ON. Then apply a simulated BFI signal to terminals 6 and 7, observing the requirements of isolated and non-isolated contact sensing. BF1, BF2, and BF3 contacts should close briefly. Also, the BF1 and BF2 targets (if supplied) should be tripped. Remove sensing input current. Reset targets (if supplied).
- Step 10. If supervisory contact sensing is supplied, perform this step. If not, continue testing with Step 11. Apply a current to any sensing input so that the current pickup indicator LED is ON. Apply a simulated BFI signal to terminals 6 and 7 and a simulated 52a (supervisory) signal to terminals 8 and 9, observing the requirements of contact sensing. BF1, BF2, and BF3 contacts should close briefly. Also, the BF1 and BF2 targets should be tripped. Reset targets (if supplied).
- Step 11. If an instantaneous output is not supplied, omit all remaining tests. If supplied, provide a monitor for contact terminals 11 and 12. For current operated targets, use at least 0.2 A current flowing through the contacts.
- Step 12. Set switch S1-1 to ON and all other switches (S1-2 through S1-8) to OFF.
- Step 13. With no current applied to any sensing inputs, apply a simulated BFI signal to terminals 6 and 7. Instantaneous contacts should close briefly and the INST target should be tripped. Reset target.
- Step 14. If supervisory contact sensing is supplied, open switch S1-1 and S1-2. With no current applied to any sensing inputs, apply a simulated supervisory signal to terminals 8 and 9. Instantaneous contacts should close briefly and INST target should be tripped. Reset target.

This page intentionally left blank.



ROUTE 143, BOX 269
HIGHLAND, IL 62249 USA
<http://www.basler.com>, info@basler.com

PHONE +1 618-654-2341

FAX +1 618-654-2351